

JST
Crimp

2.0mm
(.079") pitch

SAN CONNECTOR

Board-in Crimp style connectors

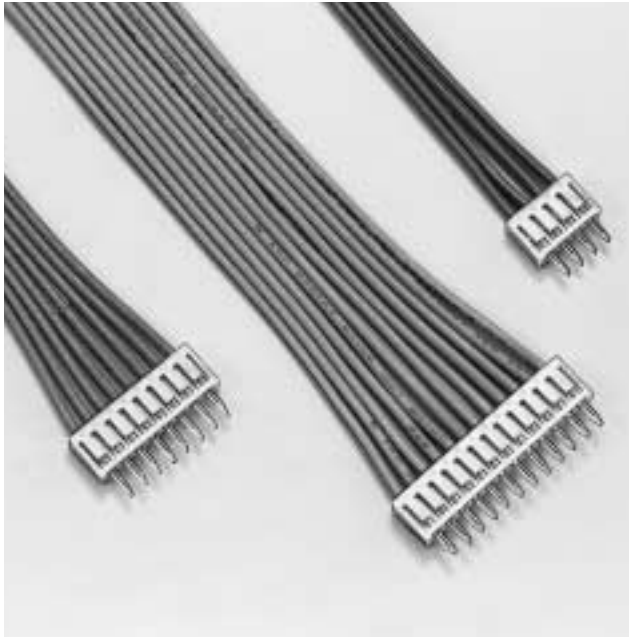

Measuring 2.0mm (.079") in pitch, 6.0mm (.236") in mounting height, and 3.25mm (.128") in thickness, this board-in connector meets the needs for high-density mounting on printed circuit boards efficiently and economically.

The connector is ideal for VCRs, car stereo systems, audio products and many other consumer oriented electronic products.

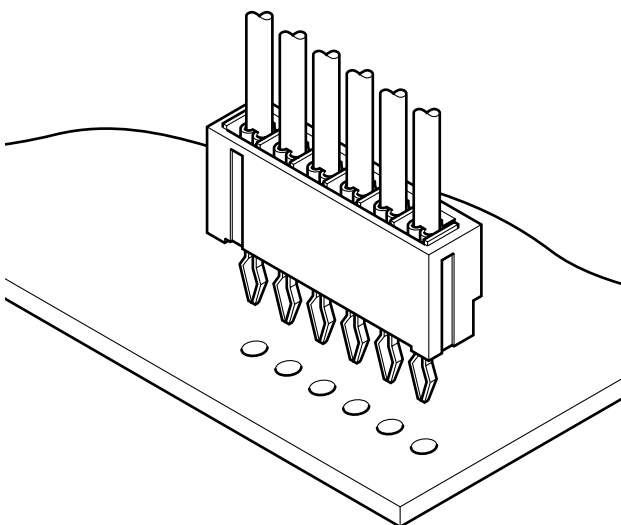

Features

• Compact

This connector measures 2.0mm (.079") in pitch, 6.0mm (.236") in mounting height, and 3.25mm (.128") in thickness. Its compact size allows high-density mounting on printed circuit boards.

• Housing lances

The lances on the resilient housing ensure easy insertion and secure locking of the contact into the housing.

• Easy mounting onto printed circuit boards

The solder tails of the contact is resilient so as to ensure easy assembly and to provide a secure lock of the connector in the printed circuit board prior to soldering.

• Two types of contacts

Two types of contacts are available according to application.

Type A

The solder tail of this contact is split in two for greater elasticity. This promotes easy insertion and secure mounting on printed circuit boards. This contact can be used for two different thickness of printed circuit boards. [1.6mm (.063") and 1.2mm (.047") thick].

Type B

The solder tail of this contact is joined at the tip. This extra support prevents breakage and ensures easy handling.

Specifications

- Current rating: 2A AC, DC (AWG#24)
- Voltage rating: 250V AC, DC
- Temperature range: -25°C to +85°C
(including temperature rise in applying electrical current)
- Insulation resistance: 1,000M min.
- Withstanding voltage: 800V AC/minute
- Applicable wire: AWG #30 to #24
- Applicable PC board thickness:
 - Type A contact: 1.2(.047")
1.6(.063")
 - Type B contact: 1.6(.063")

* Contact JST for details.

Standards

 Recognized E60389

 Certified LR20812

 R9251673

SAN CONNECTOR

Contact

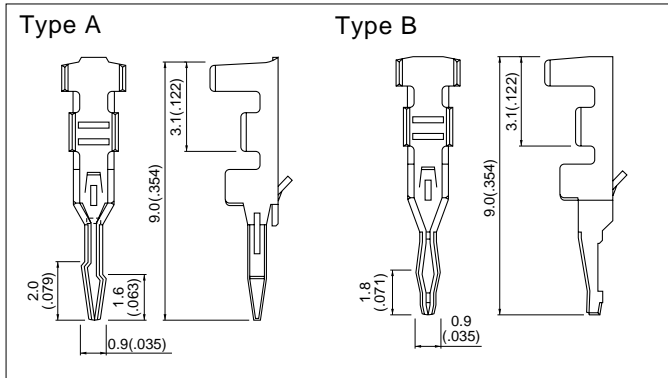

Model No.	Type	Applicable wire			Q'ty/ reel
		mm ²	AWG #	Insulation O.D.mm(in.)	
SAN-002T-0.8A	A	0.05 to 0.22	30 to 24	0.9 to 1.3(.035 to .051)	14,000
SAN-002T-0.8K	B				

Material and Finish

Brass, tin-plated

Note:

Contact JST if you require shielded wires, thin wires or other special wires.

Housing

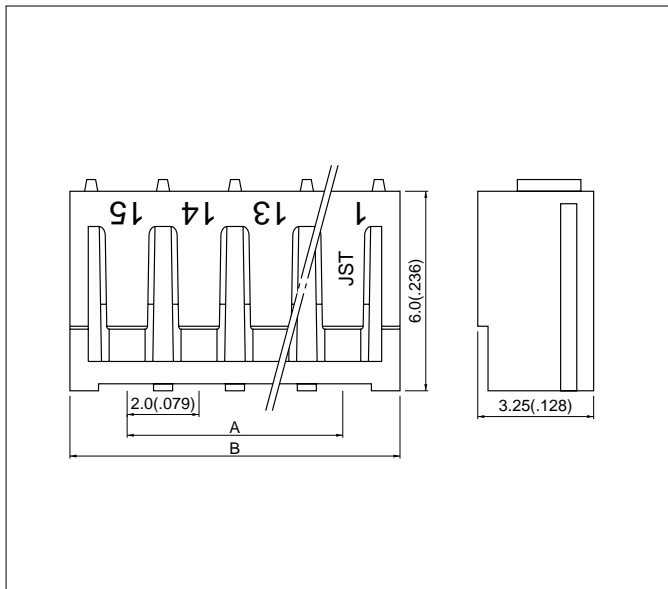

Circuits	Model No.	Dimensions mm(in.)		Q'ty / bag
		A	B	
2	2P-SAN	2.0(.079)	5.2(.205)	1,000
3	3P-SAN	4.0(.157)	7.2(.283)	1,000
4	4P-SAN	6.0(.236)	9.2(.362)	1,000
5	5P-SAN	8.0(.315)	11.2(.441)	1,000
6	6P-SAN	10.0(.394)	13.2(.520)	1,000
7	7P-SAN	12.0(.472)	15.2(.598)	1,000
8	8P-SAN	14.0(.551)	17.2(.677)	1,000
9	9P-SAN	16.0(.630)	19.2(.765)	1,000
10	10P-SAN	18.0(.709)	21.2(.835)	1,000
11	11P-SAN	20.0(.787)	23.2(.913)	1,000
12	12P-SAN	22.0(.866)	25.2(.992)	1,000
13	13P-SAN	24.0(.945)	27.2(1.071)	1,000
14	14P-SAN	26.0(1.024)	29.2(1.150)	1,000
15	15P-SAN	28.0(1.102)	31.2(1.228)	1,000

Material

Nylon 66, UL94V-0, yellow

PC board layout (viewed from soldering side) and Assembly layout

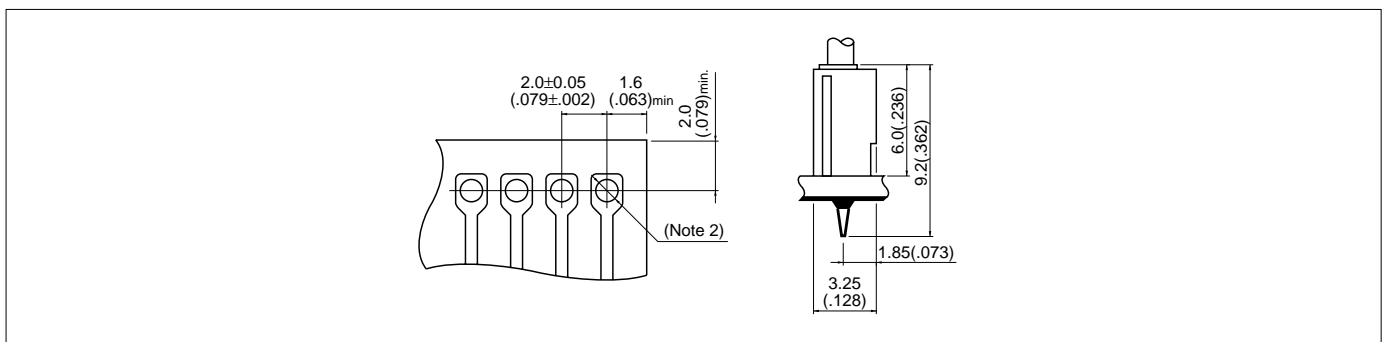

Note:

1. Tolerances are non-cumulative: $\pm 0.05\text{mm}$ ($\pm .002''$) for all centers.

*Type A $0.8^{+0.1}_{-0.05}$ ($.031^{+.004}_{-.002}$) dia.

*Type B 2 to 7 circuits: 0.75 ± 0.05 ($.030 \pm .002$) dia.
8 to 15 circuits: 0.8 ± 0.05 ($.031 \pm .002$) dia.

2. Hole dimensions differ according to the kind of PC board and piercing method. The dimensions above should serve as a guideline. Contact JST for details.

Applicator for the semi-automatic press AP-K2N

Contact	Crimp applicator MKS-L		Compact crimp applicator MKS-LS		Strip-crimp applicator MKS-SC
	with safety cover	without safety cover	with safety cover	without safety cover	with safety cover
SAN-002T-0.8A	APLMK SAN002-08	APLNC SAN002-08	APLMKLS SAN002-08	APLLSNC SAN002-08	APLSC SAN002-08
SAN-002T-0.8K	APLMK SAN002-08	APLNC SAN002-08	APLMKLS SAN002-08	APLLSNC SAN002-08	APLSC SAN002-08